

RIKEN

Anesthetic Gas Monitor

Model FI-21

Instruction Manual



RIKEN KEIKI CO., LTD.

2-7-6 Azusawa Itabashi-ku Tokyo, 174-8744, Japan

Phone : Tokyo (03) 3966-1113

Telex : 272 2638 RKNFNE

Fax : (03) 3558-9110 GIII

Cable : RIKENFINE TOKYO

Initially

Thank you for applying the Model FI-21. This instrument is a portable gas monitor to measure four of the anesthetic gases in air or O₂ intermittently.

This instruction manual is a guidebook how to operate the Model FI-21. Not only beginner users but also experienced users have to read this manual and start the operation after understanding the contents well.

To help your safety operation, the following marks are applied in this manual.



Danger

It means the matter that causes a serious damage on human beings directly.



Warning

If the instrument is operated not following by the manual, it causes a serious damage on human beings or objects.



Caution

If the instrument is operated not following by the manual, it causes some damage on human beings or objects.

* Note

Advice on usage

Index

1. PART AND THE FUNCTION.....	4
2. MEASURING MODE (POWER KEY).....	6
2-2. PROCEDURES FROM POWER ON TO MEASUREMENT.....	7
2-3. SAVING DATA.....	9
2-4. INITIAL DISPLAY (SELF-DIAGNOSTIC DISPLAY).....	9
2-5. ERROR MESSAGE DISPLAY.....	10
2-6. AIR CAL. CAUTION.....	11
2-7. AFFECTION ON MEASUREMENT FROM PRESSURE.....	12
3. SETTING MODE (ENTER + POWER).....	14
3-1. CHANGING THE MEASURING GAS (SELECT GAS).....	14
3-2. ADJUSTING THE TIME (SET DATE / TIME).....	15
3-3. CONFIRMING THE SAVED DATA (VIEW SAVED DATA).....	15
3-4. CLEARING THE SAVED DATA (CLEAR SAVED DATA).....	15
3-5. START THE MEASUREMENT (START MEAS .).....	15
4. MAINTENANCE.....	16
4-1. REPLACING THE BATTERIES.....	16
4-2. CONFIRMING THE SENSITIVITIES.....	16
4-3. DAILY CHECK.....	16
4-4. FREQUENCY / STANDARD FOR REPLACING PARTS.....	17
5. DISPOSING THE INSTRUMENT.....	17
6. TROUBLE SHOOTING.....	18
7. CAUTION ON USAGE.....	19
8. DEFENITION OF TERMS.....	20
9. SPECIFICATIONS.....	21
9-1. SPECIFICATIONS.....	21
9-2. STANDARD ACCESSORIES.....	22
9-3. WARRANTY.....	22
10. MEASURING PRINCIPLE.....	23

1. Part and the Function

TOP

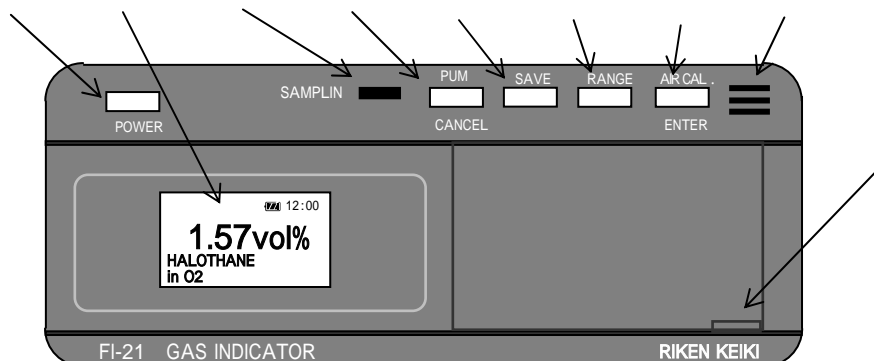

	<p>POWER key: Press this key one time to turn the power on. Keep pressing the key approx. 3 seconds to turn the power off. When pressing the POWER key and ENTER key, you can enter the "SETTING MODE".</p>
	<p>LCD Display: Concentration is displayed. And also, time, battery remainder, measuring gas and base gas are displayed.</p>
	<p>LED for "SAMPLING": While the internal pump is working, this LED is on.</p>
	<p>PUMP key (CANCEL): When this key is pressed once, the internal pump starts to work. When the key is pressed again, the pump stops. (Pump is automatically OFF after 3 minutes operation to save power consumption.) (Contents selected by 「 , keys」 are cancelled by this key.)</p>
	<p>SAVE key (key): Information about Time/ Date, Measuring Gas, Base Gas, Displayed Concentration is saved by this key. The maximum number of data points is 100. (This key is used to enter numbers or to move the cursor.)</p>
	<p>RANGE key (key): Position of the decimal point on the concentration display can be moved by this key. (This key is used to enter numbers or to move the cursor.)</p>
	<p>AIR CAL. key (ENTER key) When calibration is performed with standard gas, this key is used. (Contents selected by 「 , keys」 are fixed by this key.)</p>
	<p>Buzzer It beeps when the power turns on/off, or when special control or wrong operation is performed.</p>
	<p>There is a data logger interface under the cover.</p>

* Explanations in the () are for use during SETTING MODE.

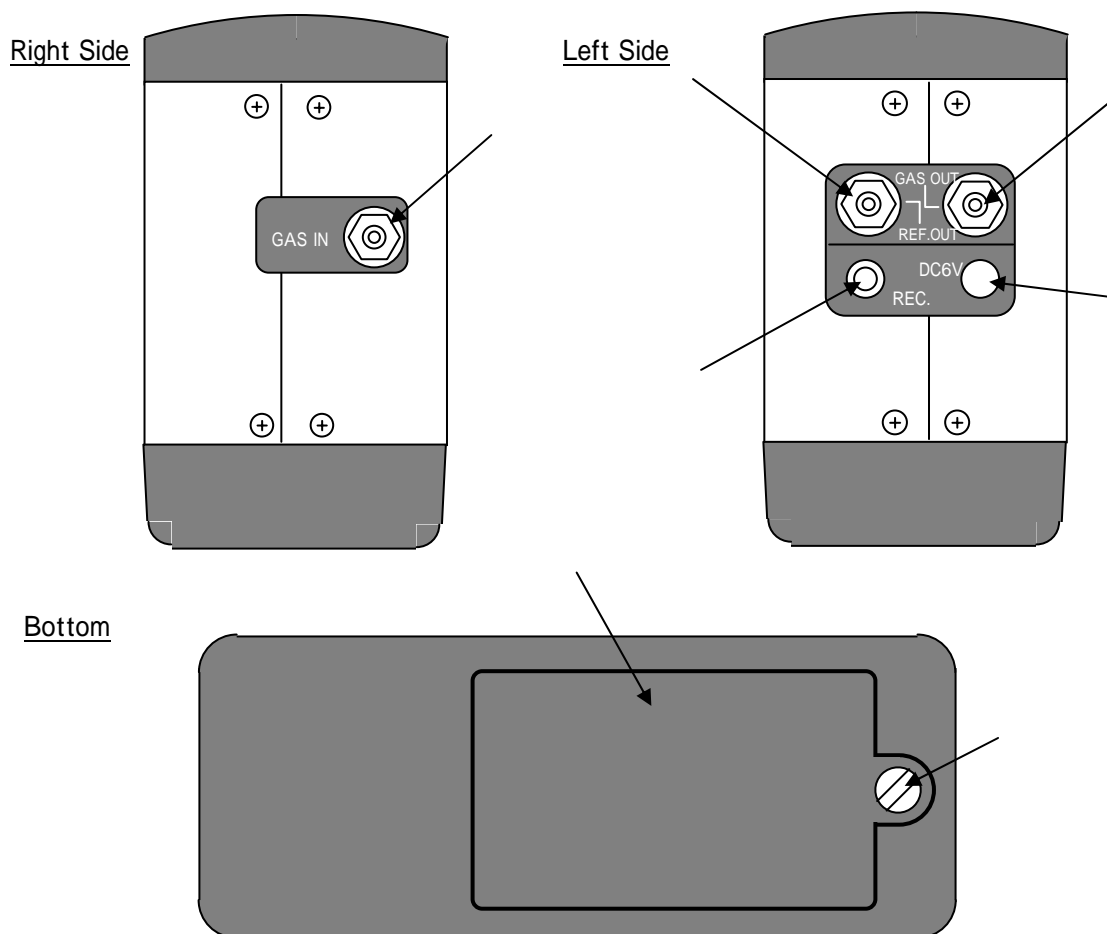

GAS IN	Inlet for measuring gas. A specific absorption tube must be connected to the inlet. Otherwise, the reading might go wrong.
REF. OUT	Outlet connected to the reference gas chamber. The exhaust from the outlet has to be emitted into the fresh air at atmospheric pressure.
GAS OUT	Outlet for measuring gas sucked from the GAS IN.
DC6V	6VDC Interface for the specific AC adaptor.
REC.	A jack for 0 - 1VDC output.
Battery Cover	Cover for the battery box.
Screw	Fixing screw for the battery cover. It can be open/ close by a screwdriver or coin.

Tubing Structure

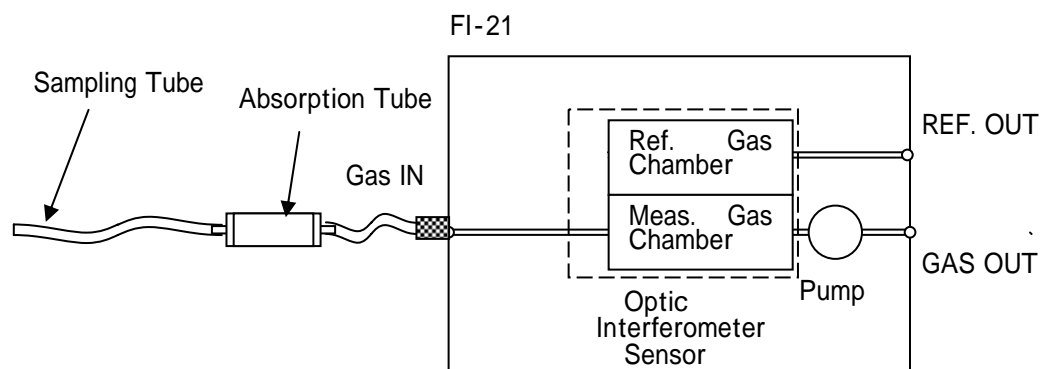

2. MEASURING MODE (POWER key)

2-1. Basic Display for Measuring Mode and Explanation

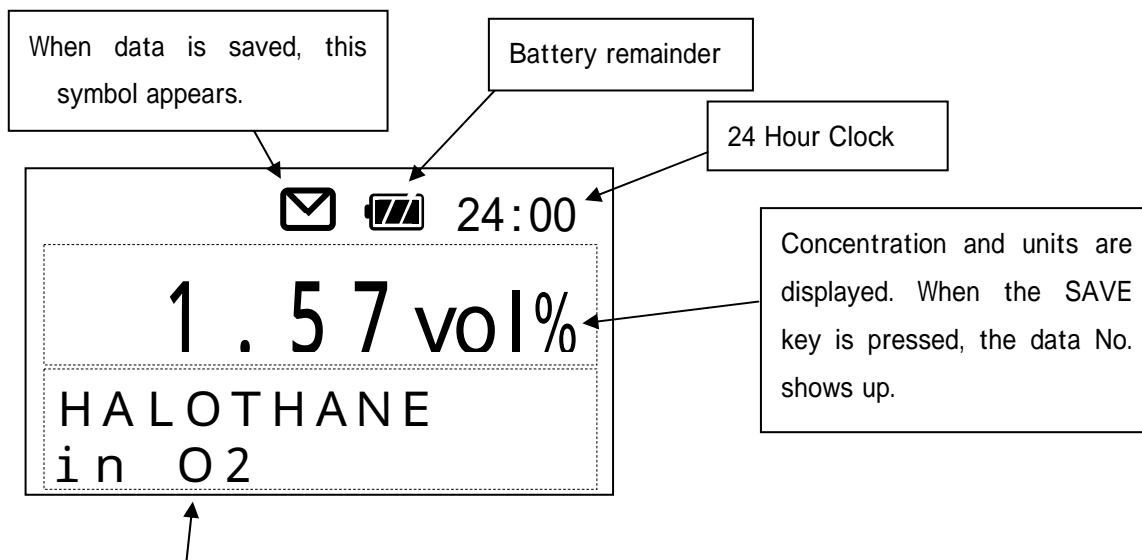

Display Contents	Status
Gas Name And Base Gas	Usual measuring mode.
CAUTION CHECK AIR CAL.	Zero drifting might be occurring. Let the monitor sample the fresh air and perform AIR CAL.
CAUTION ABNORMAL TEMP.	Internal thermistor detects an abnormal temperature.
CAUTION LOW BATT.	Battery voltage is low. Replace the batteries.
CAUTION LOW CONTRASUT	Interferometer sensor is getting contaminated. Before the measurement is performed, the sensor should be replaced or repaired.
CAUTION LOW BRIGHTNESS	Brightness is getting low. Before the measurement is performed, the sensor should be replaced or repaired.



Caution

When a message "CAUTION ~ " appears on the LCD, make an appropriate treatment as soon as possible.

2-2.Procedures from Power ON to Measurement

1) Power turns on by pressing the POWER key until buzzer beeps. And, the initial display (self-diagnostic display) shows up. It then turns to a display to confirm the setting. After showing the confirmation display for 2 seconds, it goes to the basic display of measuring mode.

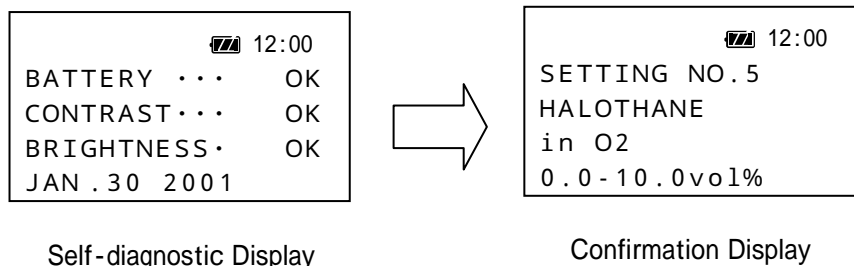

Caution

This instrument does not indicate a correct reading if the measuring gas and base gas are not selected properly. Confirm if [Measuring Gas] and [Base Gas] are the ones intentionally selected.

2) After that, two of the messages, [Meas Gas/ Base Gas] and [Air CAL], are displayed by turn as below. (Refer to WARNIN AIR CAL.)

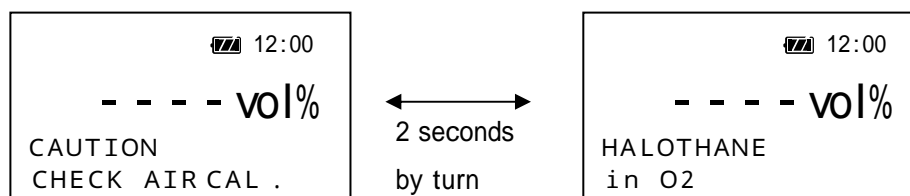

3) Press the PUMP Key and let it sample enough reference gas (fresh air). (The color of the display reverses while the pump is operating.)

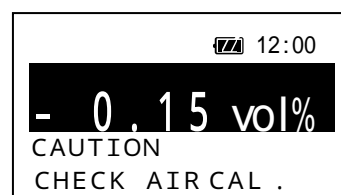

4) After the indication becomes stable, stop the pump and keep pressing the AIR CAL key until buzzer beeps.

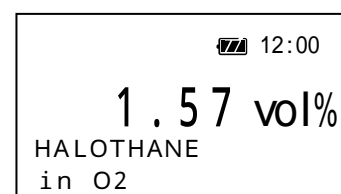

- 5) After AIR CAL., set the instruments so that it can monitor objective gas, and press PUMP key. The color of the display reverses while the pump is operating. Indication while the pump operating is not the result of monitoring.
- 6) Press PUMP key and stop the pump after indication become stable, and read the indication. The indication under the condition that the pump and sample gas flow have stopped is the monitoring result.



Caution

Press AIR CAL key after confirming there is enough fresh air in the chamber. Otherwise, correct measurement cannot be performed.

* Note

If the [AIR] is selected as the base gas, the indication shows [0.00vol%] when the AIR CAL key is pressed. However, if the [O2] is selected as the base gas, the indication does not show 0.00vol%, but other values determined based on the combination of the measuring gas and the base gas. This is caused by sampling the gas which is not on target. (In this case, it is air.) Do not think it broken. Once the instrument samples the target gas, it shows a correct reading. For further information, refer to the spec pages.



Caution

FI-21 performs best when both Gas Chamber and Reference Chamber are at the atmospheric pressure (101.3kPa). While the measuring gas is being sampled, the pressure in the Gas Chamber becomes slightly different from the atmospheric pressure, and the analyzer does not show the correct reading. Read the indication after the gas flow stops.

* Note

FI-21 measures the gas best when both Gas Chamber and Reference Chamber are at 101.3kPa. If precise measurement is required, perform the pressure correction by the following method.

$$\text{Pressure Correction} = \frac{101.3 \text{ [kPa]}}{\text{Pressure at measurement [kPa]}} \times (\text{Reading} - \text{Air Cal. Value}) + \text{Air Cal Value}$$

2-3. Saving Data

Once the SAVE key is pressed, the buzzer beeps and the display shown on the right comes up. The time/ data and the measurement result are saved chronologically from No.001 to No. 100. The saved data can be seen at “VIEW SAVED DATA” in the SETTING MODE. Also, the saved data is deleted at “CLEAR SAVED DATA” in the SETTING MODE.



2-4. Initial Display (Self-diagnostic Display)

At starting with the MEASURING MODE by pressing POWER Key the self-diagnostic function automatically starts to work. If the result is normal, display shown on the right side is displayed.

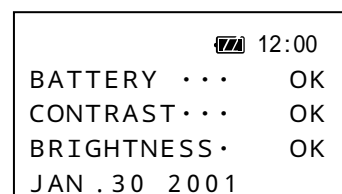

If any problem was found on any of the items, it is indicated like the display on the right. The display is an example for contamination of the interferometer. If the problem becomes serious, the display does not go to the Basic Display of the Measuring Mode, but go to ERROR message display.

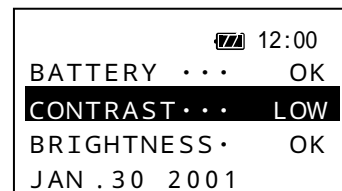

2-5. ERROR Message Display

If the problem affects the measurement, ERROR message like the display shown on the right appears.

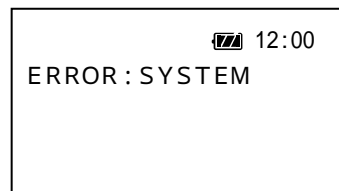

ERROR message and the meanings are as follows:

Contents of Display	The Meanings and the Required Treatments
ERROR:LOW BATT .	Battery voltage is too low to perform the measurement. Replace the batteries.
ERROR:CONTRAST	Contamination of the optic interferometer sensor is too serious to perform the measurement. Replace the sensor or have it repaired.
ERROR:BRIGHTNESS	The brightness is too low to perform the measurement. Replace the sensor or have it repaired.
ERROR:SETTING	The setup data saved in the setting mode has an error. Confirm the setup data in the setting mode, and set the data again.
ERROR:SYSTEM	A system error has occurred. Repair work is required.
ERROR:PUMP	There is a possibility that the pump is not working. Pump replacement is required.

2-6. AIR CAL. CAUTION

If the temperature inside of the sensor has changed over ± 10 from the last time the AIR CAL was performed, [CAUTION/ CHECK AIR CAL] is displayed in order to protect from zero drifting. ([Measuring Gas/ Base Gas] and [AIR CAL] are displayed consecutively.

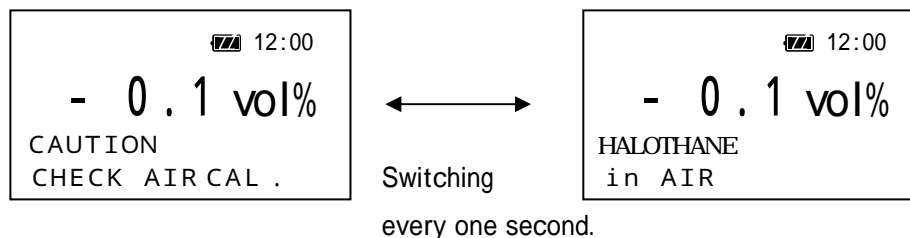

If the [CAUTION/ CHECK AIR CAL]: is displayed, perform the AIR CAL based on the procedure below:

AIR CAL. Procedure

1. Press the PUMP key and let it sample some fresh air.
2. When the indication becomes stable, stop the pump with PUMP key and press the AIR CAL key



Caution

Before pressing the AIR CAL key, let the instrument sample enough fresh air. (ideally for 2 minutes.) Otherwise, correct measurement cannot be performed.



Caution

Whenever measurement starts, confirm if the AIR CAL value is displayed after fresh air is sampled enough. If the AIR CAL. Value is not indicated (or even if [AIR CAL CAUTION] is not displayed), perform the AIR CAL procedures by correct method.

2-7. Affection on Measurement from Pressure



CAUTION

The pressure in the Gas Chamber becomes different from the atmospheric pressure whiling sampling the gas. As a result, the indication is not accurate. Or, if an instant pressure change occurs in the Gas Chamber or the Reference Chamber, the indication might go wrong. (If these symptoms occurs, perform the AIR CAL right away.) Therefore, take care about the following points:

- > Do not plug the GAS IN or GAS OUT while gas is feeding.
- > Keep the pressure of GAS IN, GAS OUT, and REF. OUT equal to the atmospheric pressure when the indication is read.
- > Read the indication after the gas flow stops.



CAUTION

When concentration change occurs suddenly on the FI-21, correct reading cannot indicate. Absorption tube is not only for removing the humidity, but also for stabilizing the temperature of the sampling gas. Therefore, equip an absorption tube on the GAS IN whenever the measurement is performed.

An example of measurement when the pressure of the sampling point is higher than the atmospheric pressure:

Make an inlet (a) as the drawing below. Open and shut the stop valve to feed the gas to the instrument, instead of turning the pump on and off. Read the indication after shutting the valve off and the gas flow totally stops. Flow rate at Inlet (a) should be 300 to 400mL.

GAS OUT should be at the atmospheric pressure and the REF. OUT should face with fresh air.

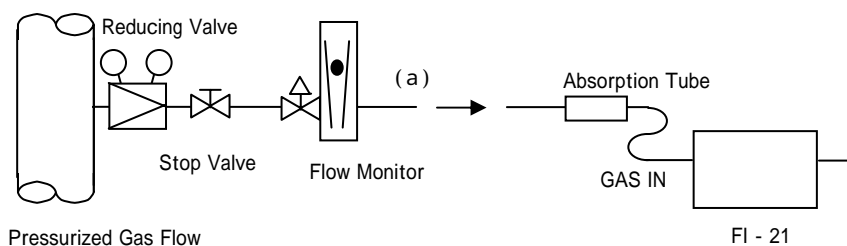

An example of measurement when the measured gas is not released in to the air:

Connect a gas sampling bag to the GAS OUT, not to emit the exhaust into the air. And also, expose the REF. OUT to the fresh air.

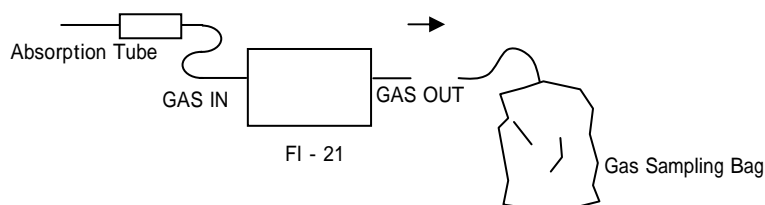

3. SETTING MODE (ENTER + POWER)

The SETTING MODE is for “Change the Measuring Gas”, “Adjusting the Time”, and “Confirming the Saved Data”. You enter the SETTING MODE by pressing the POWER key while the ENTER key is being pressed.

Once you enter the mode, the display on the right shows up. Move the cursor (black bar) by keys and select the item which you would like to setup. Go into the item by [ENTER key].

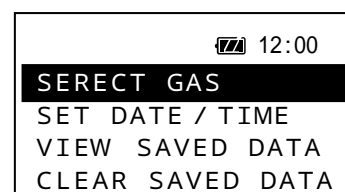

Initial Display in Setting Mode

Items to Setup and the Contents

SELECT GAS	Changing the measuring gas, the base gas and the output.
SET DATE / TIME	Adjusting the clock
VIEW SAVED DATA	Confirming saved data
CLEAR SAVED DATA	Clearing the saved data
START MEAS.	Starting the Measuring Mode.

3-1. Changing the Measuring Gas (SELECT GAS)

Choose the measuring gas by the [] key and presse ENTER key to fix the choice. On the 1st line, a sentence “IS SETTING OK?” apperears. Press [ENTER] key again if it is okay. If you want to change the setting, press the [CANCEL] key.

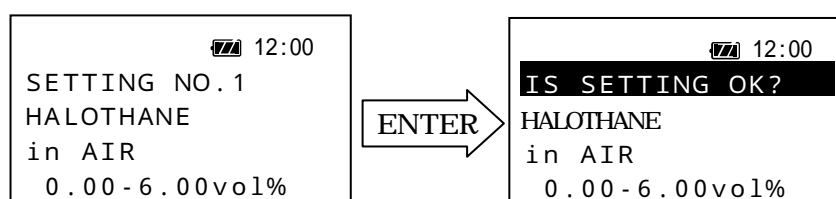

Select by keys.

If the setting is what you intend, press the ENTER key to save the setting.

3-2. Adjusting the Time (SET DATE / TIME)

Initial position of the cursor is on MONTH. Choose by keys and fix the setting by the ENTER key. The cursor then moves to DAY. Set DAY, YEAR, HOUR and MINUTE by the same procedures as MONTH. HOUR is displayed by 24 hour clock.

```

12:00
DATE
JAN 30 2001
TIME
12:00

```

3-3. Confirming the Saved Data (VIEW SAVED DATA)

On the 1st line, the data number is shown. On the 2nd to 3rd line, the saved date/ time are displayed. Select the date number by [] key and fix the selection by [ENTER] key. The saved data then comes up. (At displaying the saved data, the measuring gas and the base gas is displayed with white letters on black background.) (CANCEL key leads to the initial display in Setting Mode.)

```

12:00
NO .001
DATE: JAN .30 2001
TIME: 16:32
+ ENTER

```



```

12:00
4.13 vol%
HALOTHANE
in O2 NO.001

```

3-4. Clearing the Saved Data (CLEAR SAVED DATA)

Select the "CLEAR SAVED DATA" by key and fix the selection by ENTER key. If you want to cancel the action, select "CANCEL" and press the [ENTER] key.

```

12:00
CANCEL
CLEAR SAVED DATA

```

3-5. Start the Measurement (START MEAS .)

If you want to start the measurement right after setting each item, select "START MEAS" and press [ENTER] key. The display will then go to the Measuring Mode.

```

12:00
CANCEL
START MEAS .

```

4. Maintenance

4-1. Replacing the Batteries



Warning

- > All the C size Alkaline batteries used in the instrument should be same kind.
- > Replace the 4 of the batteries at the same time.

- 1) Confirm that the power is off.
- 2) Take out the instrument from the carrying case.
- 3) Take off the battery cover under the bottom by turning the screw with a coin.
- 4) Take out the old batteries and put the new ones caring the polarities.
- 5) When the replacement is done, put the battery cover on the bottom by the opposite procedures.

4-2. Confirming the Sensitivities

It is recommended that the sensitivity of the instrument be confirmed periodically (at least once a year) to assume the correct operation. The procedures for the sensitivity confirmation are as follows: If any problem is found, or If you would like to have it calibrated, please contact any of our agents.

- 1) Select “DESFLURANE in AIR 0-20vol%” and go into the measuring mode.
- 2) Perform the AIR CAL as it is done for the usual measurements.
- 3) Feed some pure CO₂ (at 99.999% +) to the instrument.
- 4) Perform the Air Correction by the following calculation:

$$\text{Result of the Air Correction [vol\%]} = \frac{101.3[\text{ kPa }]}{\text{Atmospheric Press at Measurement [kPa]}} \times \text{Indication Value[vol\%]}$$

- 5) If the result of the Air Correction is 15.66 ± 0.47 [vol%], the sensitivity is normal.

4-3. Daily Check

- 1) Is there any damage on switches, lamps, display or body?
- 2) Confirmation of battery voltage.
- 3) Do you see “CAUTION ...” or “ ERROR...” during the operation?

4-4.Frequency / Standard for Replacing Parts

The frequency of the replacement mentioned below is just a standard. The available term totally depends on how often the instrument is used and how it is stored.

1) Internal pump and internal tubing	2 years
2) Absorption Tube (consumable part)	2 years
3) Rubber parts in Interferometer	2 years (Optic element should be cleaned if necessary.)
4) Main PCB	5 years
5) Interferometer Assembly	5 years (continuously used if no problem.)
6) Others	5 years

5. Disposing the Instrument

This instrument does not apply any harmful material as component parts. When the instrument is disposed, take an appropriate method based on the local regulation.

6. Trouble Shooting

Trouble shootings mentioned below do not cover all the problems. The ones considered frequently occur are simply indicated to help your research for cause and solution.

Symptoms	Causes	Solutions
Power does not turn ON.	<p>No batteries. Or, AC adaptor is not connected.</p> <p>Polarity of the batteries is wrong.</p> <p>Time to press the POWER Key is short.</p>	<p>Put the batteries in. Or, connect AC adaptor.</p> <p>Put the batteries in correct direction.</p> <p>Keep pressing the POWER key until the buzzer beeps.</p>
Reading is not correct.	<p>AIR CAL is not performed in a correct way.</p> <p>The selected "Measuring Gas" or "Base Gas" is wrong.</p> <p>Interference gas is included in the sample gas.</p> <p>A sudden pressure change occurs at GAS IN, GAS OUT or REF. OUT.</p> <p>The pressure at GAS IN, GAS OUT or REF. OUT is not at atmospheric pressure.</p>	<p>When the instrument samples enough fresh air, stop the pump. Then, press the AIR CAL key.</p> <p>Select the correct "Measuring Gas" and "Base Gas".</p> <p>The target gas that contains interference gas cannot be measured.</p> <p>Perform AIR CAL again.</p> <p>Set GAS IN, GAS OUT and REF. OUT under the atmospheric pressure.</p>
After performing AIR CAL, the reading goes up even though any gas is not fed.	Molecular attached to the chamber inside or tubing inside starts detaching. The concentration in chamber becomes high in fact.	Let the instrument sample enough fresh air. And confirm if it shows the AIR CAL value.

7. Caution on Usage

The following caution items must be followed to maintain the performance/ safety of the instrument.



Danger

- > Specification of this instrument is based on a non-explosion structure. Do not use it in a place specified as a hazardous area.
- > Make any solutions for exhaust gas emitted from GAS OUT, to avoid harmful gas from emission. (e.g. Connecting a sampling bag to GAS OUT.)
- > Just in case of leaking from the instrument itself, wearing a mask and gloves is recommended.



Warning

- > The instrument shows incorrect indication when it samples a high concentration gas over the full scale.
- > Use the batteries based on the specifications.
- > Use the specified AC adaptor if necessary.



Caution

- > Do not use this instrument close to other apparatus that generates a strong noise. It may affect the wave form of the power source. If the AC adaptor is applied, do not use the same power source as other apparatus that generates a strong noise.
- > Use the power source based on the specifications.
- > Do not operate the instrument in a place which has a reaction heat such as infrared emitted from high temperature. Or, Avoid a place which has a direct sunbeam that makes the instrument over 35C.
- > Interference Gas: The gases which are neither the target gas nor base gas.
If there is any interference gas in the measuring gas, the reading goes wrong. Do not measure the gas which contains interference gas.
- > Let GAS OUT and REF. OUT expose to the air, in order to equal the pressure inside to the atmospheric pressure.
- > Whenever this instrument operates, keep it in a carrying case and connect the absorption tube.

8. Defenition of Terms

- vol% : The rate of substance occupying in some volume. The unit is indicated by percentage.
- Measuring Gas : The target gas to measure in the sample gas.
- Base Gas : The balance gas in the sample gas.
- Reference Gas : The gas (fresh air) to take the standard reflection ratio.
- Gas Chamber : Chamber that is filled by sample gas.
- Reference Gas Chamber : Chamber that is filled by reference gas.
- AIR CAL VALUE : Concentration indicated on the display when AIR CAL key is pressed.

9. Specifications

9-1. Specifications

Model	Model FI-21															
Measuring Gas	O2 Base: Halothane, Isoflurane, Sevoflurane, Desflurane Air Base: Halothane, Isoflurane, Sevoflurane, Desflurane															
Reference (Standard) Gas	Air															
Dimensions	145 (H) × 200 (W) × 80 (D) (mm)															
Weight	Approx. 2 kg															
Power Source	C size Alkaline Battery (4 ea.), or AC Adaptor (Option)															
Display Contents	Measuring Gas, Base Gas, Concentration, Time, etc.															
Measuring Ranges	<p>The number in () is the minimum displayable digit. [Unit: vol%]</p> <table border="1"> <thead> <tr> <th>Measuring Gas \ Base Gas</th> <th>Halothane</th> <th>Isoflurane</th> <th>Sevoflurane</th> <th>Desflurane</th> </tr> </thead> <tbody> <tr> <td>Air</td> <td>0 ~ 6 (0.01)</td> <td>0 ~ 8 (0.01)</td> <td>0 ~ 10 (0.01)</td> <td>0 ~ 20* (0.02)</td> </tr> <tr> <td>O2</td> <td>0 ~ 6 (0.01)</td> <td>0 ~ 8 (0.01)</td> <td>0 ~ 10 (0.01)</td> <td>0 ~ 20* (0.02)</td> </tr> </tbody> </table> <p>* The gas does not vaporize easily. Therefore, the concentration may not be able to reach the full scale.</p>	Measuring Gas \ Base Gas	Halothane	Isoflurane	Sevoflurane	Desflurane	Air	0 ~ 6 (0.01)	0 ~ 8 (0.01)	0 ~ 10 (0.01)	0 ~ 20* (0.02)	O2	0 ~ 6 (0.01)	0 ~ 8 (0.01)	0 ~ 10 (0.01)	0 ~ 20* (0.02)
Measuring Gas \ Base Gas	Halothane	Isoflurane	Sevoflurane	Desflurane												
Air	0 ~ 6 (0.01)	0 ~ 8 (0.01)	0 ~ 10 (0.01)	0 ~ 20* (0.02)												
O2	0 ~ 6 (0.01)	0 ~ 8 (0.01)	0 ~ 10 (0.01)	0 ~ 20* (0.02)												
(AIR CAL. Value)	<p>AIR CAL. Value = Indication when the instrument detects the fresh air. [Unit: vol%]</p> <table border="1"> <thead> <tr> <th>Measuring Gas \ Base Gas</th> <th>Halothane</th> <th>Isoflurane</th> <th>Sevoflurane</th> <th>Desflurane</th> </tr> </thead> <tbody> <tr> <td>Air</td> <td>0.00</td> <td>0.00</td> <td>0.00</td> <td>0.00</td> </tr> <tr> <td>O2</td> <td>1.57</td> <td>1.65</td> <td>1.70</td> <td>2.10</td> </tr> </tbody> </table>	Measuring Gas \ Base Gas	Halothane	Isoflurane	Sevoflurane	Desflurane	Air	0.00	0.00	0.00	0.00	O2	1.57	1.65	1.70	2.10
Measuring Gas \ Base Gas	Halothane	Isoflurane	Sevoflurane	Desflurane												
Air	0.00	0.00	0.00	0.00												
O2	1.57	1.65	1.70	2.10												
(Drifting Value)	<p>Drifting value of indication which might be generated when the ambient temperature changes ±10 . [Unit: vol%]</p> <table border="1"> <thead> <tr> <th>Measuring Gas \ Base Gas</th> <th>Halothane</th> <th>Isoflurane</th> <th>Sevoflurane</th> <th>Desflurane</th> </tr> </thead> <tbody> <tr> <td>Air</td> <td>0.09</td> <td>0.09</td> <td>0.10</td> <td>0.12</td> </tr> <tr> <td>O2</td> <td>0.09</td> <td>0.09</td> <td>0.09</td> <td>0.12</td> </tr> </tbody> </table>	Measuring Gas \ Base Gas	Halothane	Isoflurane	Sevoflurane	Desflurane	Air	0.09	0.09	0.10	0.12	O2	0.09	0.09	0.09	0.12
Measuring Gas \ Base Gas	Halothane	Isoflurane	Sevoflurane	Desflurane												
Air	0.09	0.09	0.10	0.12												
O2	0.09	0.09	0.09	0.12												
Accuracy	± (Reading -) × 0.03 ±															
Operating Temp. & Humidity	5 ~ 35 , Below 80%RH															
Battery Life	Approx. 30 hours (when the pump works 50% of the total operating time.)															
Outputs	Data Logger, 0 ~ 1VDC Analog Output															
Data Logging Function	Concentration Reading with Month/ Day/ Year and Time Maximum Recording Number: Up to 100															

9-2. Standard Accessories

1) Carrying Case	1 each
2) Absorption Tube (Calcium Chloride included)	1 each
3) Sampling Probe	1 each
4) Instruction Manual	1 each

9-3. Warranty

RIKEN KEIKI CO., LTD. warrants gas alarm equipment manufactured and sold by us to be free from defects in materials and workmanship for a period of one year from the date of shipment from RIKEN KEIKI. Any parts found defective within that period will be repaired or replaced at our option, free of charge, FOB factory. This warranty does not apply to those items which by their nature are subject to deterioration or consumption in normal service, and which must be cleaned, repaired or replaced on a routine basis. Such items may include:

- a) Lamp bulbs and fuses
- b) Pump diaphragms and valves
- c) Absorbent cartridges
- d) Filter elements
- e) Batteries

Warranty is voided by abuse including rough handling, mechanical damage, operation, alteration, or repair procedures not in accordance with instruction manual. This warranty indicates the full extent of our liability, and we are not responsible for removal or replacement costs, local repair costs, transportation cost, or contingent expenses incurred without our prior approval.

THIS WARRANTY IS EXPRESSLY IN LIEU OF ANY AND ALL OTHER WARRANTIES AND REPRESENTATIONS, EXPRESSED OR IMPLIED. AND ALL OTHER OBLIGATIONS OR LIABILITIES ON THE PART OF RIKEN KEIKI CO., LTD. INCLUDING BUT NOT LIMITED TO, THE WARRANTY OF MERCHANTABILITY OR FITNESS FOR A PARTICULAR PURPOSE. IN NO EVENT SHALL RIKEN KEIKI CO., LTD. BE LIABLE FOR INDIRECT, INCIDENTAL OR CONSEQUENTIAL LOSS OR DAMAGE OF ANY KIND CONNECTED WITH THE USE OF ITS PRODUCTS OR FAILURE OF ITS PRODUCT TO FUNCTION OR OPERATE PROPERLY.

This warranty covers instruments and parts sold (to users) only by authorized distributors, dealers and representatives as appointed by RIKEN KEIKI CO., LTD.

We do not assume the indemnification for any accident or damage caused by the operation of this gas monitor and our warranty is limited to the replacement of parts or our complete goods.

10. Measuring Principle

Reflection ratio of gas mixture is determined by the kinds of the composing gases and the mixture ratio. As long as the kinds of composing gases are known, the mixture ratio (concentration) can be determined by measuring the reflection ratio.

The optic interferometer applied in the FI-21 displays "Interference Stripes" on the CCD. The Interference stripes move proportional to reflection ratio. The amount of the movement is measured by solution of the interference stripes on CCD with Fourier analysis. And the result is converted to the reflection ratio.

Concentration can be displayed by adding some data like "measuring gas" and "base gas" to the reflection ratio determined by high accuracy. Sensitivity of the optic interferometer depends on the length of the chamber. Since the length of the chamber is physically unchanged by elapsing time, the high accuracy is maintained for a long time.

